

SECTION A-A

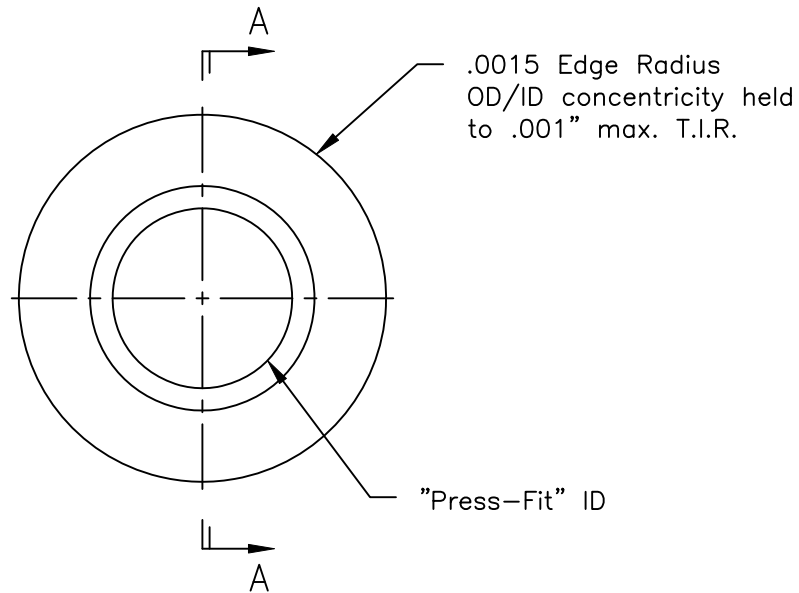

.0015 Edge Radius
OD/ID concentricity held
to .001" max. T.I.R.

"Press-Fit" ID

WEB PRINT

Our circular knives are made from 52100 steel and heat treated to a hardness of 61-63 R/C.

Other edges, materials, tolerances and hardnesses are always available for quote.

PORTAGE KNIFE
COMPANY

MANUFACTURER OF
SCORE SLITTERS
AND PERFORATORS

A DIVISION OF PORTAGE MACHINE CONCEPTS, INC. AKRON, OHIO (330) 784-0700

125-40-0015 Circular Knife

SIZE
A

DWG NAME:

W125-40-0015.dwg

SCALE: NONE

DATE: 11/27/2019

DRAWN: D. MILLER

SHEET: 1 OF 1

This print and the intellectual content is the property of Portage Machine Concepts, Inc. and must not be copied, transmitted or disseminated, in any way, without the written permission of Portage Machine Concepts, Inc.