

SECTION A-A

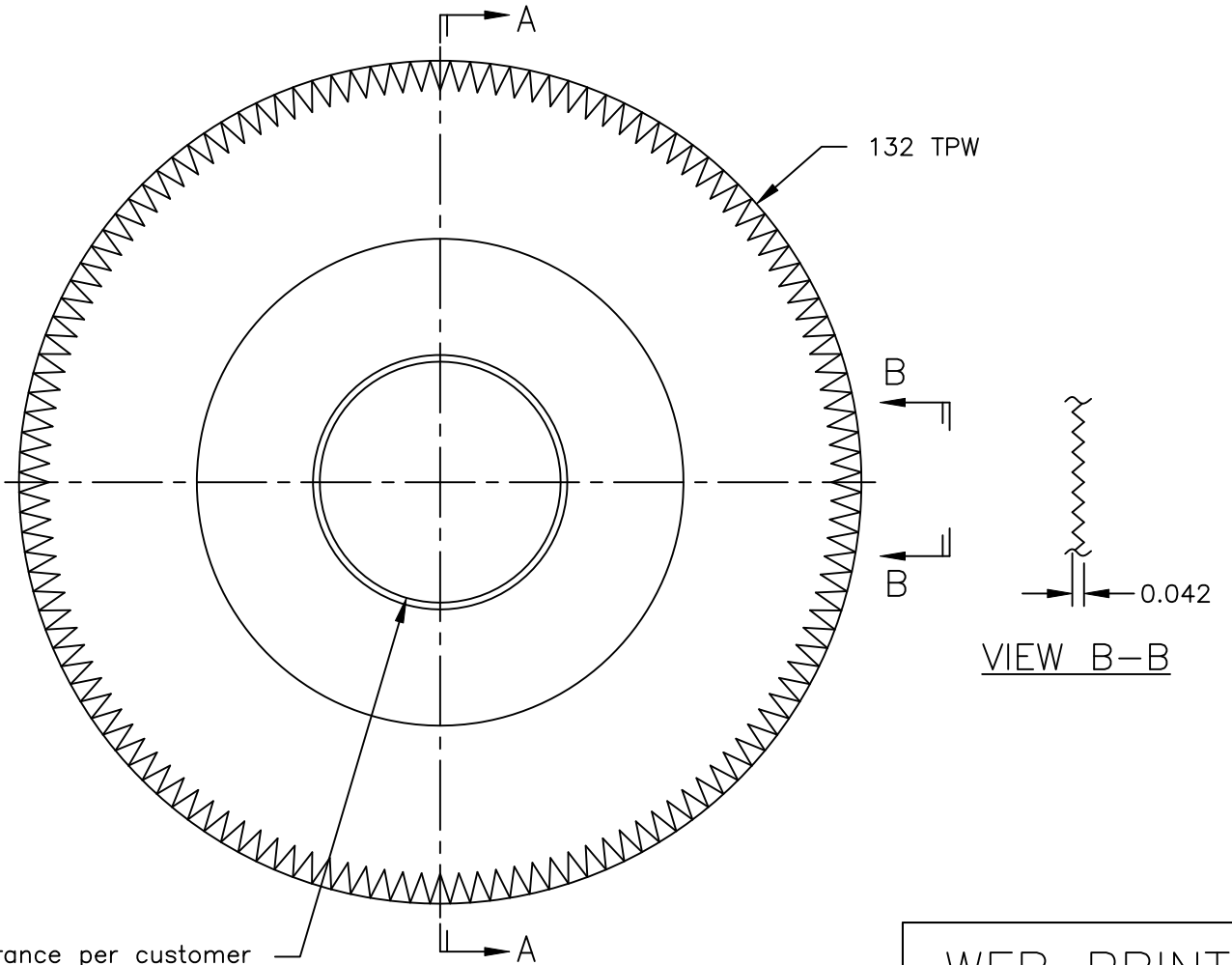

WEB PRINT

Pinker knives are typically made from 52100 or D2 steel and heat treated, to a hardness specified by customer requirements, up to 63 R/C.

PORTAGE KNIFE COMPANY MANUFACTURER OF SCORE SLITTERS AND PERFORATORS
 A DIVISION OF PORTAGE MACHINE CONCEPTS, INC. AKRON, OHIO (330) 784-0700

300P-132-042 Circular Knife

SIZE A	DWG NAME: W300P-132-042.dwg
-----------	--------------------------------

This print and the intellectual content is the property of Portage Machine Concepts, Inc. and must not be copied, transmitted or disseminated, in any way, without the written permission of Portage Machine Concepts, Inc.

SCALE: NONE	DATE: 1/25/2021	DRAWN: D. MILLER	SHEET: 1 OF 1
-------------	-----------------	------------------	---------------