

SECTION A-A

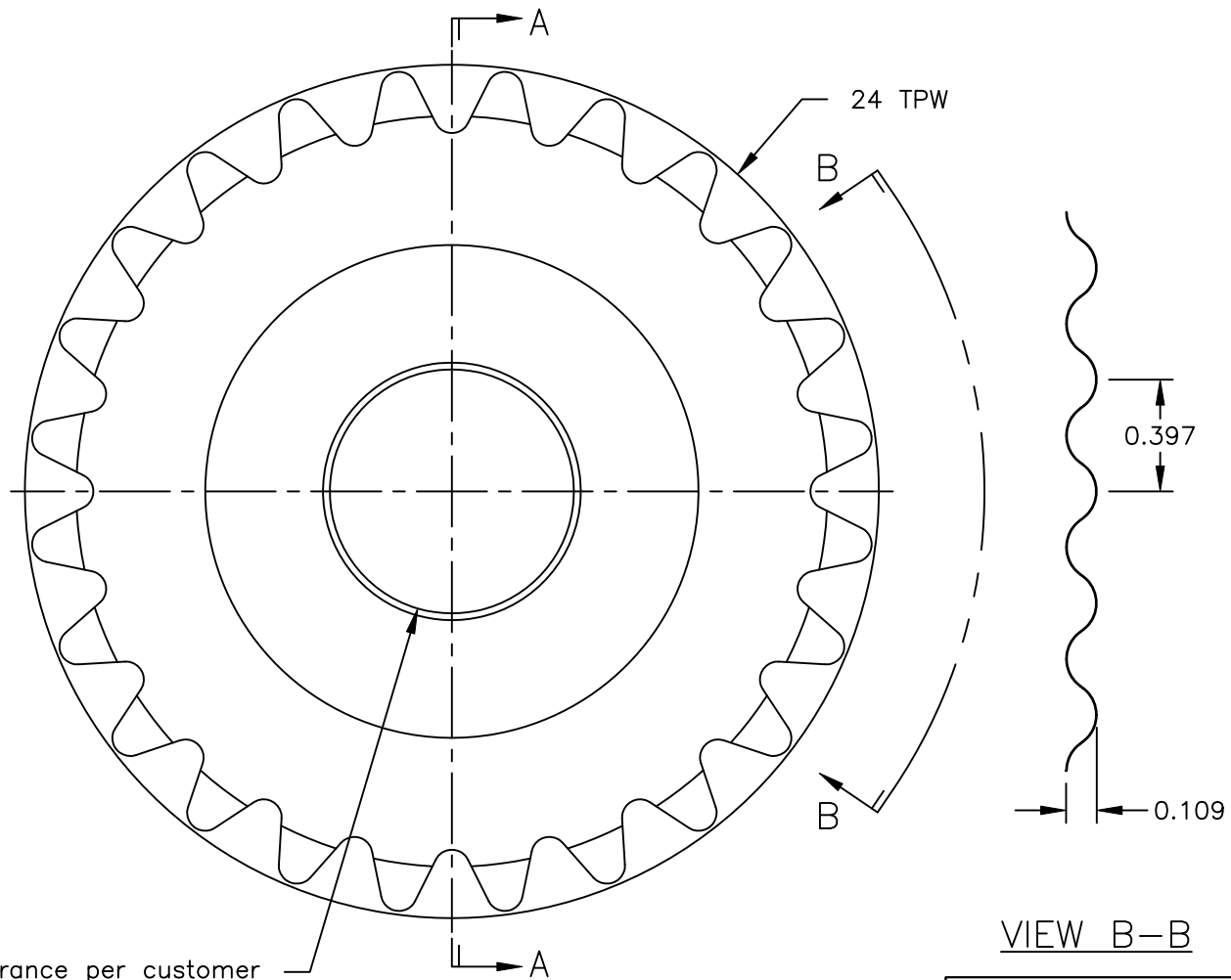

ID tolerance per customer requirements.

VIEW B-B

WEB PRINT

Scallop knives are typically made from 52100 or D2 steel and heat treated to a hardness specified by customer requirements, up to 63 R/C.

PORTAGE KNIFE COMPANY MANUFACTURER OF SCORE SLITTERS AND PERFORATORS
A DIVISION OF PORTAGE MACHINE CONCEPTS, INC. AKRON, OHIO (330) 784-0700

300S-24-109 Scallop Knife

SIZE A	DWG NAME: W300S-24-109.dwg
-----------	-------------------------------

This print and the intellectual content is the property of Portage Machine Concepts, Inc. and must not be copied, transmitted or disseminated, in any way, without the written permission of Portage Machine Concepts, Inc.

SCALE: NONE	DATE: 01/15/2020	DRAWN: D. MILLER	SHEET: 1 OF 1
-------------	------------------	------------------	---------------