

SECTION A-A

Circular knives are heat treated, to a hardness specified by customer requirements, up to 63 R/C.

Our circular knives are typically made from 52100 steel, but are also available in other tool steels such as D2 or M2. Others materials are also available for quote.

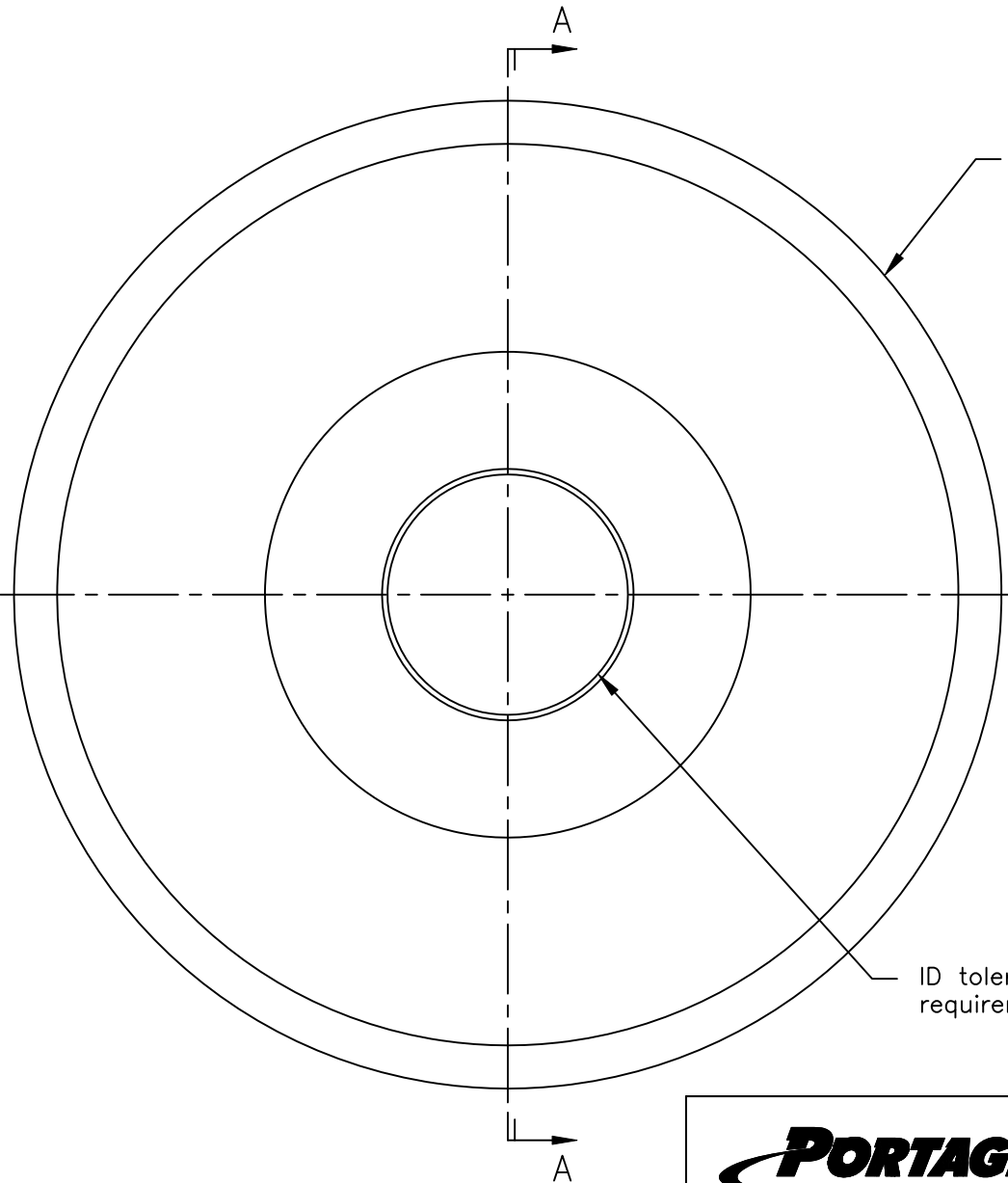

Cutting edge per customer requirements. Typically anywhere from a sharp edge up to a .007" radius.

Custom edges with other radii are also available.

ID tolerance per customer requirements.

WEB PRINT

PORTAGE KNIFE
COMPANY

A DIVISION OF PORTAGE MACHINE CONCEPTS, INC. AKRON, OHIO (330) 784-0700

MANUFACTURER OF
SCORE SLITTERS
AND PERFORATORS

358-40 Circular Knife

SIZE
A

DWG NAME:
W358-40.dwg

SCALE: NONE

DATE: 01/30/2018

DRAWN: D. MILLER

SHEET: 1 OF 1