

SECTION A-A

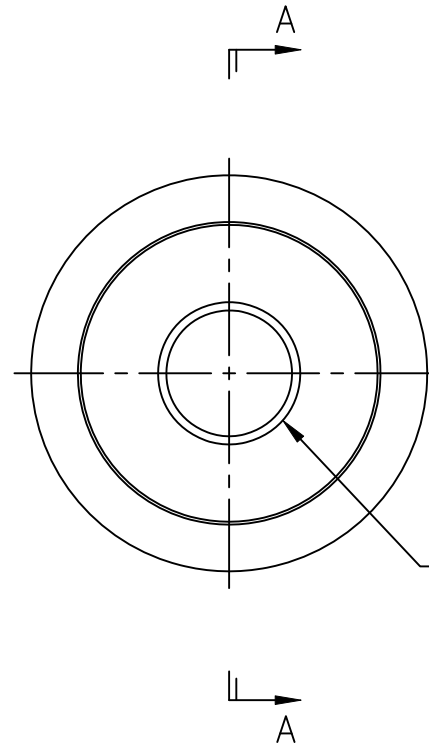

ID tolerance per customer requirements.

WEB PRINT

Circular knives are manufactured from S7, heat treated to a hardness of 57-59 R/C.

**PORTAGE KNIFE**  
COMPANY

MANUFACTURER OF  
SCORE SLITTERS  
AND PERFORATORS

A DIVISION OF PORTAGE MACHINE CONCEPTS, INC. AKRON, OHIO (330) 784-0700

137-60-001-S7 Circular Knife

SIZE  
A

DWG NAME:

W137-60-001-S7.dwg

SCALE: NONE

DATE: 2/12/2021

DRAWN: D. MILLER

SHEET: 1 OF 1