

SECTION A-A

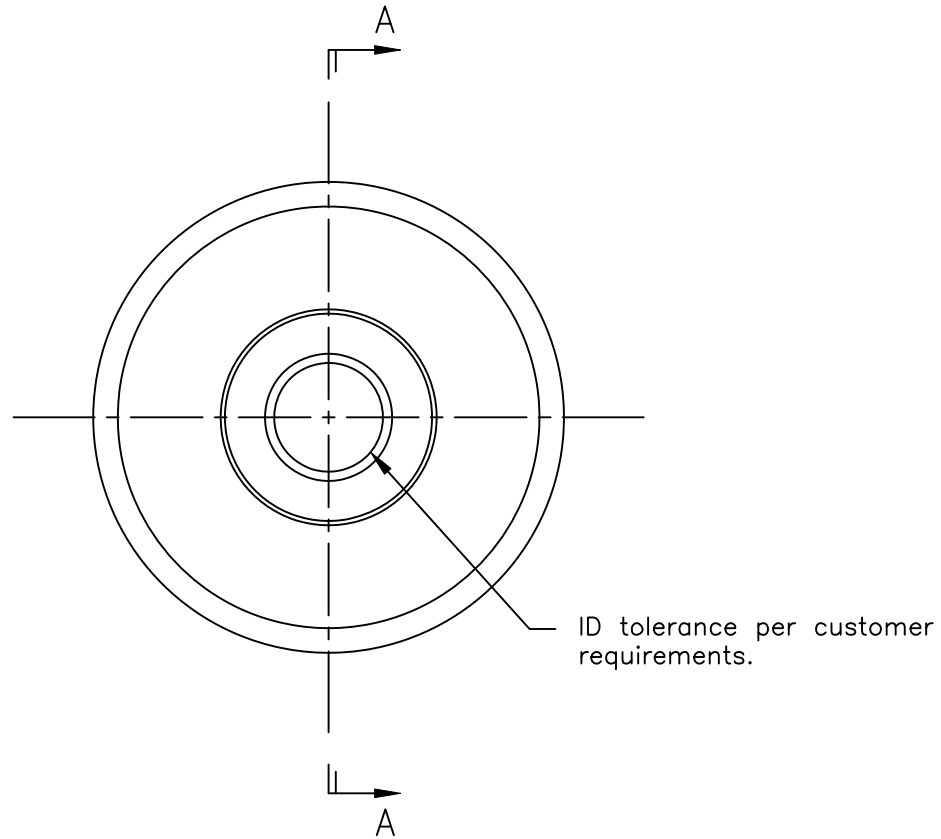

WEB PRINT

PORTAGE KNIFE MANUFACTURER OF
COMPANY SCORE SLITTERS
 AND PERFORATORS
A DIVISION OF PORTAGE MACHINE CONCEPTS, INC. AKRON, OHIO (330) 784-0700

160-40-007 Circular Knife

SIZE A	DWG NAME: W160-40-007.dwg
-----------	------------------------------

Circular knives are made from S7 material and heat treated to a hardness of 58-60 R/C.

This print and the intellectual content is the property of Portage Machine Concepts, Inc. and must not be copied, transmitted or disseminated, in any way, without the written permission of Portage Machine Concepts, Inc.

SCALE: NONE	DATE: 6/12/2018	DRAWN: D. MILLER	SHEET: 1 OF 1
-------------	-----------------	------------------	---------------