

SECTION A-A

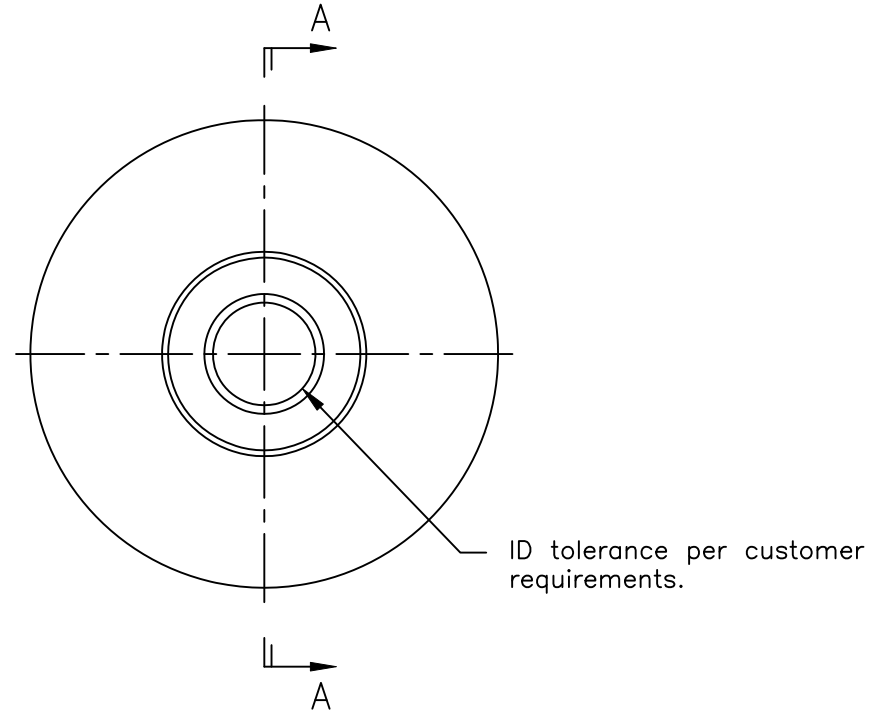

WEB PRINT

PORTAGE KNIFE COMPANY MANUFACTURER OF SCORE SLITTERS AND PERFORATORS
A DIVISION OF PORTAGE MACHINE CONCEPTS, INC. AKRON, OHIO (330) 784-0700

161-45-007-S7 Circular Knife

SIZE A	DWG NAME: W161-45-007-S7.dwg
-----------	---------------------------------

Circular knives are produced using S7 material and heat treated, to a hardness of 58-60 R/C.

This print and the intellectual content is the property of Portage Machine Concepts, Inc. and must not be copied, transmitted or disseminated, in any way, without the written permission of Portage Machine Concepts, Inc.

SCALE: NONE	DATE: 2/16/2021	DRAWN: D. MILLER	SHEET: 1 OF 1
-------------	-----------------	------------------	---------------