

SECTION A-A

Circular knives are heat treated, to a hardness specified by customer requirements, up to 63 R/C.

Our circular knives are typically made from 52100 steel, but are also available in other tool steels such as D2 and M2. Other materials are also available for quote.

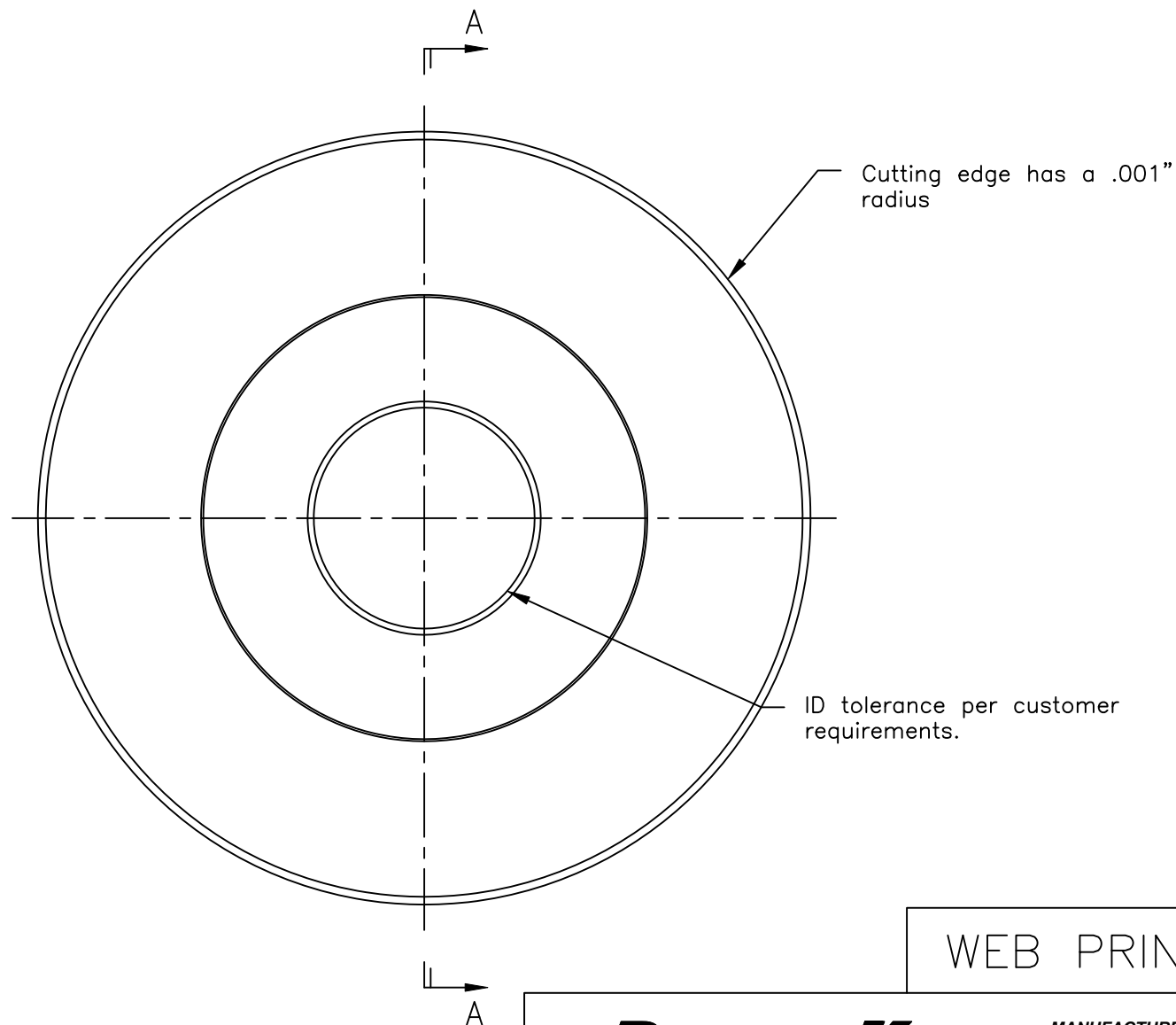

WEB PRINT

**PORTAGE KNIFE COMPANY** MANUFACTURER OF SCORE SLITTERS AND PERFORATORS  
A DIVISION OF PORTAGE MACHINE CONCEPTS, INC. AKRON, OHIO (330) 784-0700

300-45-001-Thin-C

SIZE A	DWG NAME: W300-45-001-Thin-C.dwg
-----------	-------------------------------------

This print and the intellectual content is the property of Portage Machine Concepts, Inc. and must not be copied, transmitted or disseminated, in any way, without the written permission of Portage Machine Concepts, Inc.

SCALE: NONE	DATE: 7/26/2018	DRAWN: D. MILLER	SHEET: 1 OF 1
-------------	-----------------	------------------	---------------