

SECTION A-A

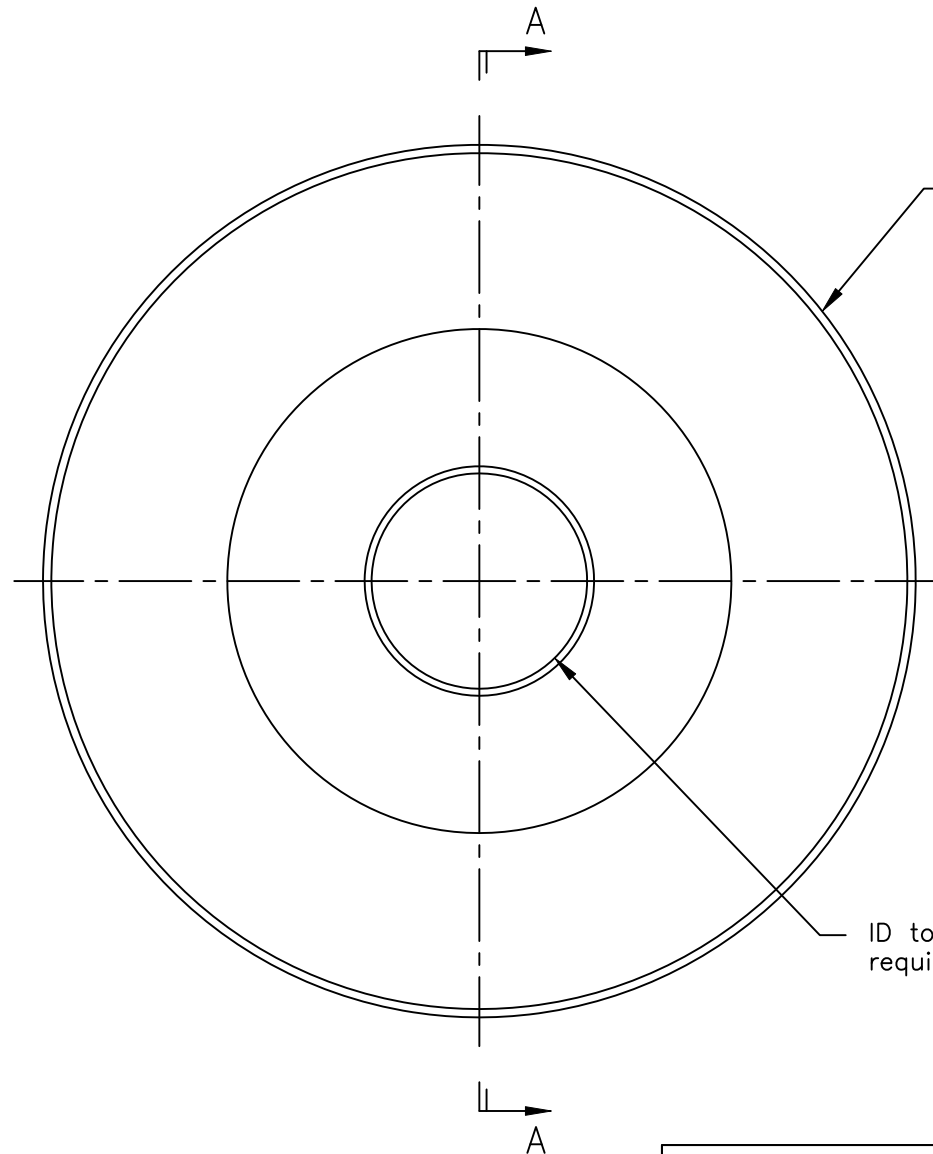

Cutting edges are typically a .002", .005" or .007" radius and offset .058" from center.

Other edges and offsets are available for quote.

ID tolerance per customer requirements.

WEB PRINT

Circular knives are heat treated, to a hardness specified by customer requirements, up to 63 R/C.

Circular knives are made from 52100 or D2 steel, but other materials are available for quote.

PORTAGE KNIFE
COMPANY

MANUFACTURER OF
SCORE SLITTERS
AND PERFORATORS

A DIVISION OF PORTAGE MACHINE CONCEPTS, INC. AKRON, OHIO (330) 784-0700

330-30-Offset Circular Knife

SIZE	DWG NAME:
A	W330-30-_058 OFFSET.dwg

This print and the intellectual content is the property of Portage Machine Concepts, Inc. and must not be copied, transmitted or disseminated, in any way, without the written permission of Portage Machine Concepts, Inc.

SCALE: NONE	DATE: 1/30/2019	DRAWN: D. MILLER	SHEET: 1 OF 1
-------------	-----------------	------------------	---------------